

## APC Case Assembly Instructions

### Step One

Press fit the four vertical supports so they snap into the APC mounting holes.

Press fit the two front supports to the front of the APC motherboard. The rocker switch should be aligned over the power button.

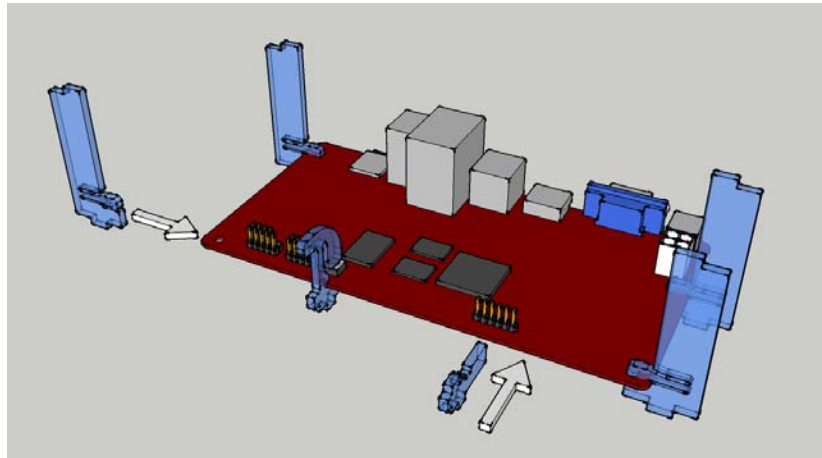

### Step Two

Lower the assembly onto the bottom plate. The bottom plate has two sets of snaps. Adjust the supports as needed so that all tabs align properly with the matching holes in the bottom plate.

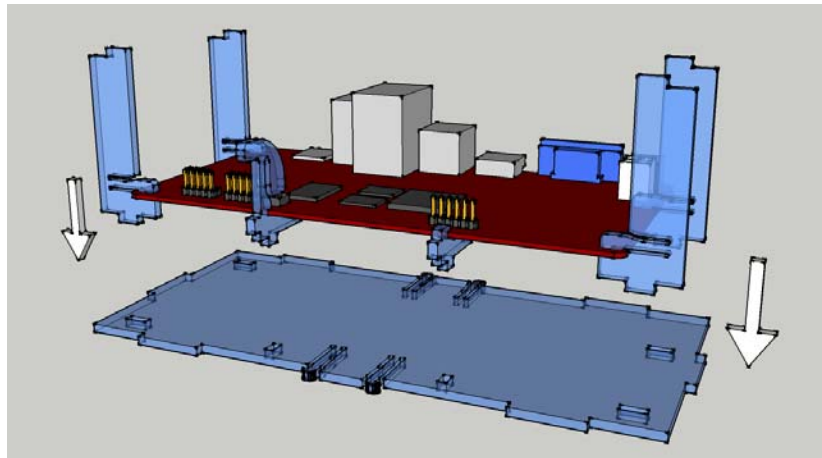

### Step Three

Lower the top plate onto the four supports. Adjust the supports as needed so that all tabs align properly with the matching holes in the top plate.

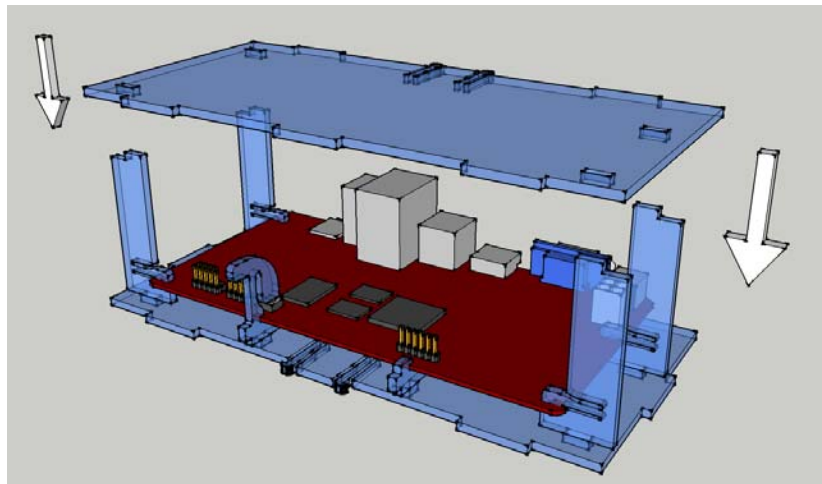

#### Step Four

Press the front plate onto the tabs that extend from the top and bottom plates. Snaps on the bottom plate will lock the front plate into place.

Make sure the rocker switch aligns properly so that it extends through the front plate.

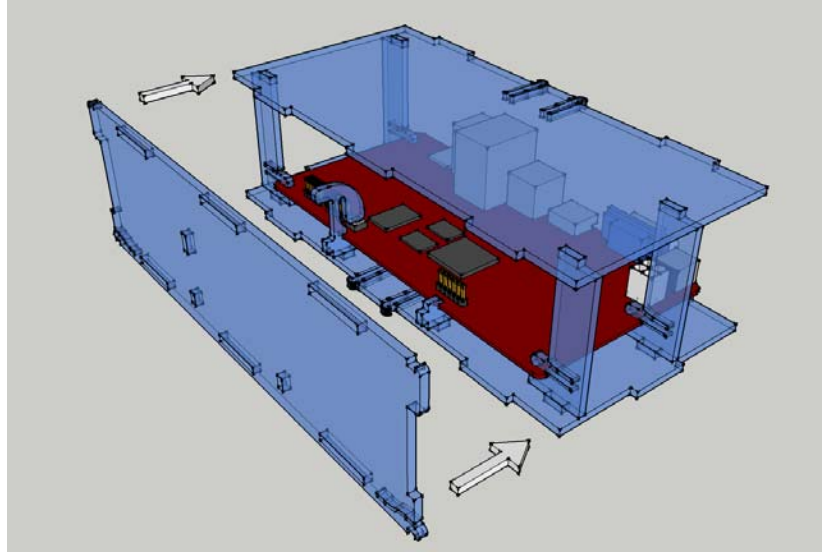

#### Step Five

Insert the metal shield (supplied with the APC) into the large opening within the back plate. Press the back plate and metal shield onto the tabs that extend from the top and bottom plates. Snaps on the top and bottom plate will lock the back plate into place.

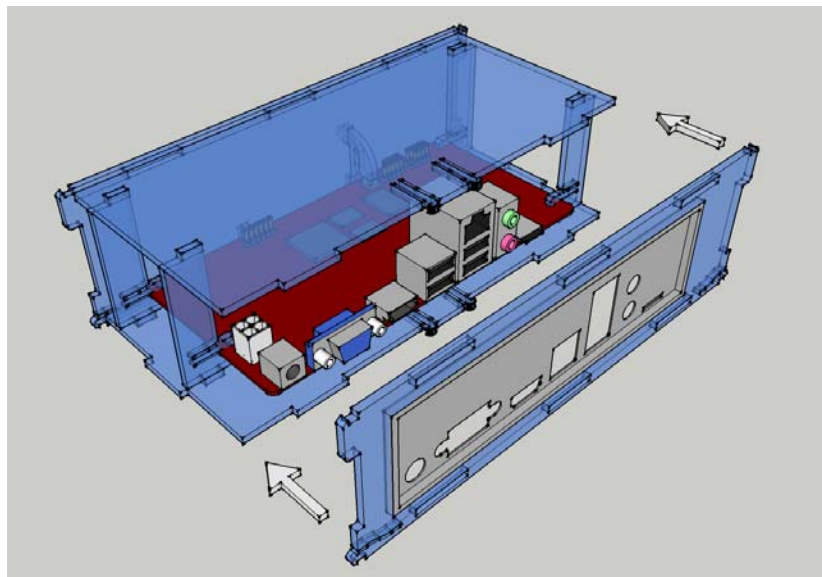

#### Step Six

Attach the side plates over the upper tabs extending from the front and back plates. Then press the bottom of the side plates until they snap into place over the hooked tabs extending from the front and back plates.

